

Genie Industries

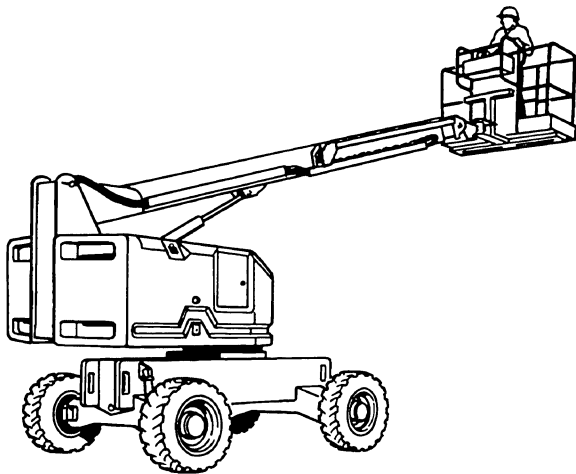

Genie® S-40

Operator's Manual



First Edition, Third Printing
Part No. 32221



32221

Genie® S-40

Important

Read, understand and obey these safety rules and operating instructions before operating this machine. Only trained and authorized personnel shall be permitted to operate this machine. This manual should be considered a permanent part of your machine and should remain with the machine at all times. If you have any questions, call Genie Industries.

Contents

	Page
Safety	1
Controls	6
Pre-operation Inspection	9
Function Tests	11
Work Place Inspection	15
Operating Instructions	16
Transport	19
Decals	20
Specifications	23

Genie North America

Telephone (206) 881-1800
Toll Free in U.S.A. 800 536-1800
Toll Free in Canada 800 426-8089
Fax (206) 883-3475

Genie Europe

Telephone (44) 01636-605030
Fax (44) 01636-611090

Genie Industries

Copyright © 1994 by Genie Industries

First Edition: First Printing February, 1994
Second Printing, February 1995
third Printing, May 1996

Genie® is a registered trademark of Genie Industries. Registered 2009987

These machines comply with ANSI/SIA 92.5-1992.

♻️ Printed on recycled paper

Printed in U.S.A.

Safety Rules



Danger

Failure to obey the instructions and safety rules in this manual will result in death or serious injury.

Do Not Operate Unless:

- You learn and practice the principles of safe machine operation contained in this operator's manual.

1 Avoid hazardous situations.

Know and understand the above principle before going on to the next section.

- 2 Always perform a pre-operation inspection.
- 3 Always perform function tests prior to use.
- 4 Inspect the work place.
- 5 Only use the machine as it was intended.

- You read, understand and obey:

Manufacturer's instructions and safety rules—safety and operator's manuals and machine decals

employer's safety rules and worksite regulations

applicable governmental regulations

- You** are properly trained to safely operate the machine.

SAFETY RULES

Electrocution Hazards

This machine is **not** electrically insulated and will **not** provide protection from contact with or proximity to electrical current.

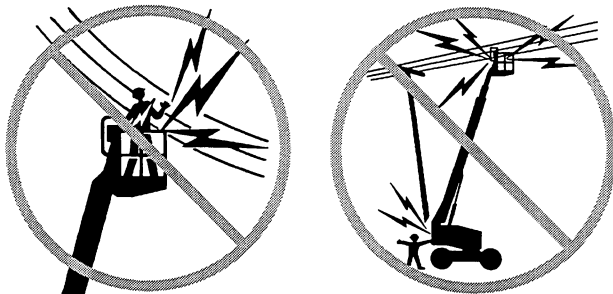

Maintain safe distances from electrical power lines and apparatus in accordance with applicable governmental regulations and the following chart.

Voltage Phase to Phase	Minimum Safe Approach Distance	
	Feet	Meters
0 to 300V	Avoid Contact	
300V to 50KV	10	3.05
50KV to 200KV	15	4.60
200KV to 350KV	20	6.10
350KV to 500KV	25	7.62
500KV to 750KV	35	10.67
750KV to 1000KV	45	13.72

Allow for platform movement, electrical line sway or sag and beware of strong or gusty winds.

Keep away from the machine if it contacts energized power lines. Personnel on the ground or in the platform must not touch or operate the machine until energized power lines are shut off.

Do not use the machine as a ground for welding.

Tip-over Hazards

Occupants and equipment shall not exceed the maximum platform capacity.

Maximum platform capacity	500 lbs	227 kg
Maximum occupants	2	

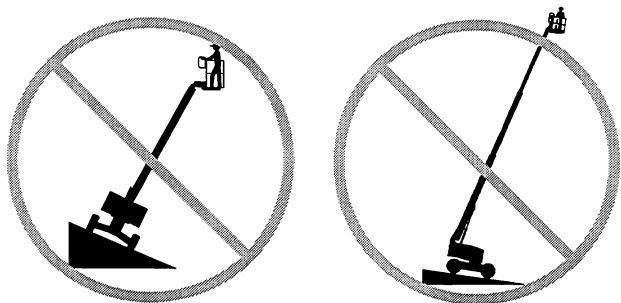

Do not raise or extend the boom unless the machine is on a firm, level surface.

Do not depend on tilt alarm as a level indicator. Tilt alarm sounds in platform only when machine is on a severe slope (4.5° or more).

If tilt alarm sounds:

Do not extend, rotate or raise boom above horizontal. Move machine to a firm, level surface before raising platform. If tilt alarm sounds when platform is raised, use extreme caution to retract boom and lower platform. Do not rotate boom while lowering. Move machine to a firm, level surface before raising platform.

SAFETY RULES

Do not raise the boom in strong or gusty winds.

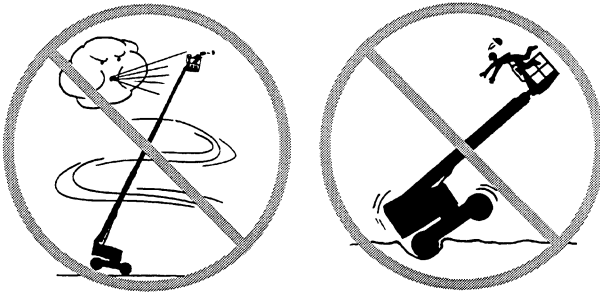

Do not place or attach overhanging loads to any part of this machine.

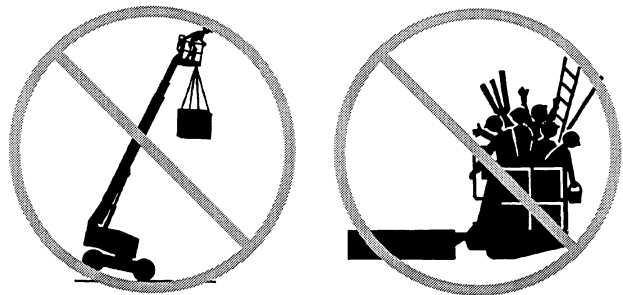

Use extreme care and slow speeds while driving the machine in stowed position across uneven terrain, debris, unstable or slippery surfaces and near holes and drop-offs.

Do not drive the machine on or near uneven terrain, unstable surfaces or other hazardous conditions with the boom raised or extended.

Do not push off or pull toward any object outside of the platform.

Do not place ladders or scaffolds in platform or against any part of this machine.

Do not use machine on a moving or mobile surface or vehicle.

Be sure all tires are in good condition, air-filled tires are properly inflated and lug nuts are properly tightened.

Maximum allowable side force	150 lbs 667 N
-------------------------------------	------------------

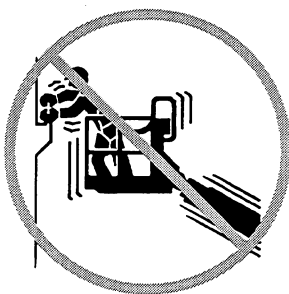

Do not alter or disable machine components that in any way affect safety and stability.

Do not replace items critical to machine stability with items of different weight or specification.

SAFETY RULES

Fall Hazards



Occupants must wear a safety belt or harness in accordance with governmental regulations. Attach lanyard to anchor provided in platform.

It is recommended that operators wear an approved hard hat when operating the machine.

Do not sit, stand or climb on the platform guard rails. Maintain a firm footing on the platform floor at all times.

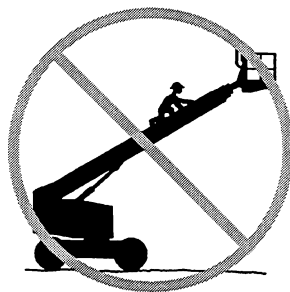

Do not climb down from the platform when raised.

Keep the platform floor clear of debris.

Lower the platform entry mid-rail or close the entry gate before operating.

Collision Hazards



Be aware of limited sight distance and blind spots when driving or operating.

Be aware of boom position and tailswing when rotating turntable.

Check work area for overhead obstructions or other possible hazards.



Be aware of crushing hazard when grasping the platform guard rail.

Observe and use color-coded direction arrows on the platform controls and drive chassis for drive and steer functions.

Do not lower the boom unless the area below is clear of personnel and obstructions.

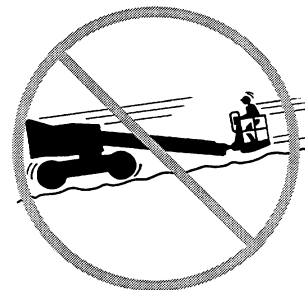

Limit travel speed according to condition of ground surface, congestion, slope, location of personnel, and any other factors which may cause collision.

Do not operate a boom in the path of any crane unless the controls of the crane have been locked out and/or precautions have been taken to prevent any potential collision.

SAFETY RULES

Component Damage Hazards

Do not use any battery or charger greater than 12V to jump-start the engine.

Do not use machine as a ground for welding.

Be sure hydraulic shutoff valves (located by hydraulic tank) are open before starting engine.

Explosion and Fire Hazards

Do not start engine if you smell or detect liquid petroleum gas (LPG), gasoline, diesel fuel or other explosive substances.

Do not refuel machine with engine running.

Refuel machine and charge battery only in an open, well-ventilated area away from sparks, flames and lighted tobacco.

Always operate machine in a well-ventilated area to avoid carbon monoxide poisoning.

Damaged Machine Hazards

Do not use a damaged or malfunctioning machine.

Conduct a thorough pre-operation inspection of the machine and test all functions before each work shift. Immediately tag and remove from service a damaged or malfunctioning machine.





Be sure all maintenance has been performed as specified in this manual and the *Genie S-40 Service Manual*.

Be sure all decals are in place and legible.

Be sure safety and operator's manuals are complete, legible and in the storage container located on the platform.

Decal Legend

Genie product decals use color coding and signal words to identify the following:

- | | |
|--|--|
|  | Red—used to indicate the presence of a hazard that will cause death or serious injury. |
|  | Orange—used to indicate the presence of a hazard that may cause death or serious injury. |
|  | Yellow—used to indicate the presence of a hazard that will or may cause serious injury or damage to the machine. |
|  | Green—used to indicate operation or maintenance information. |

Controls

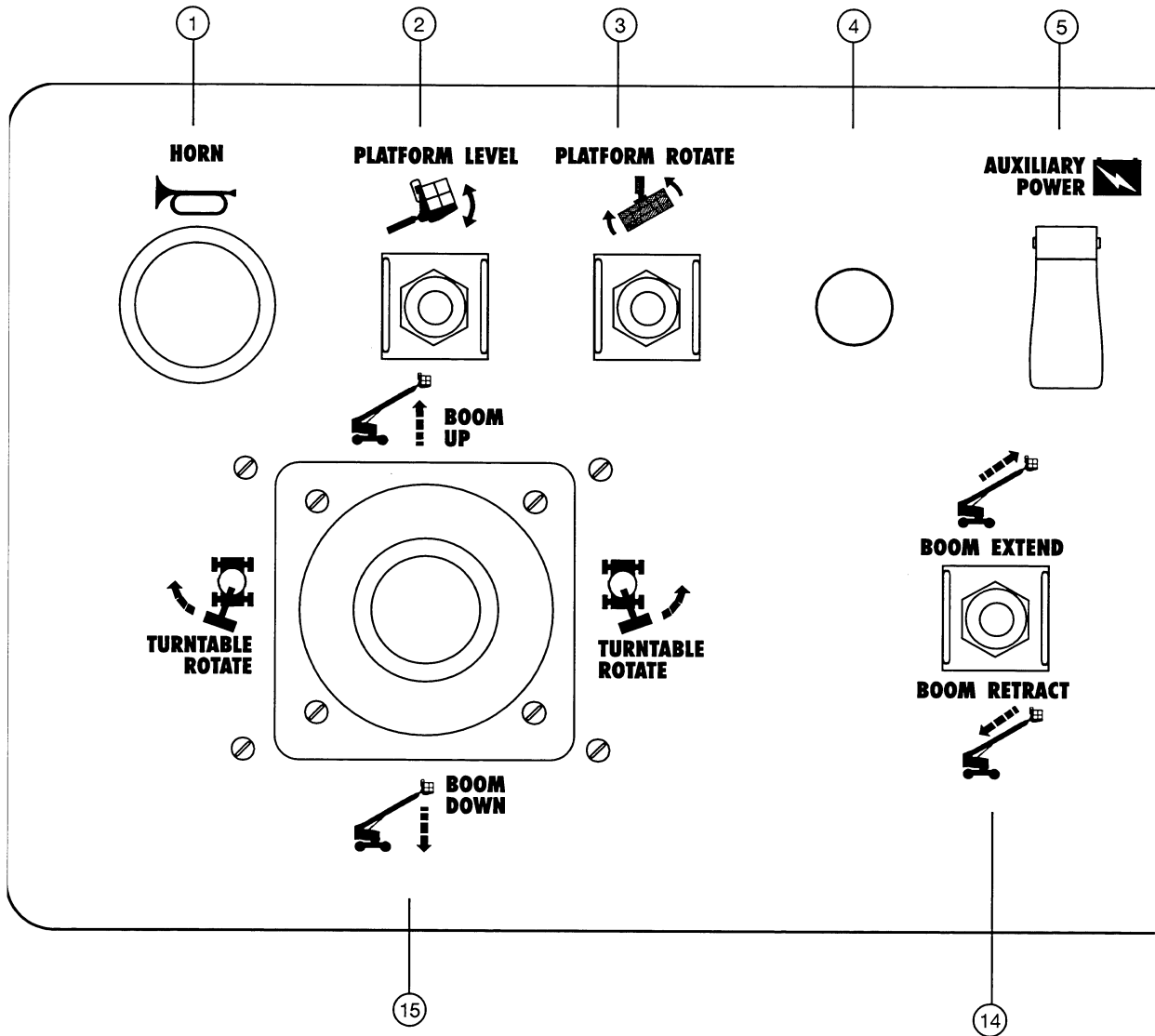

Platform Control Panel

- 1 Service horn button
- 2 Platform level switch
- 3 Platform rotate switch
- 4 not used
- 5 Auxiliary power switch with cover
- 6 Generator/functions select switch (option)
- 7 Engine start switch
- 8 Engine idle (rpm) select switch
 - Rabbit & Foot Switch: foot switch activated high idle
 - Turtle: low idle
 - Rabbit: high idle
- 9 Gasoline/LPG models: Gasoline/LPG select switch
Deutz Diesel models: Glow plug switch
- 10 Emergency Stop button

CONTROLS

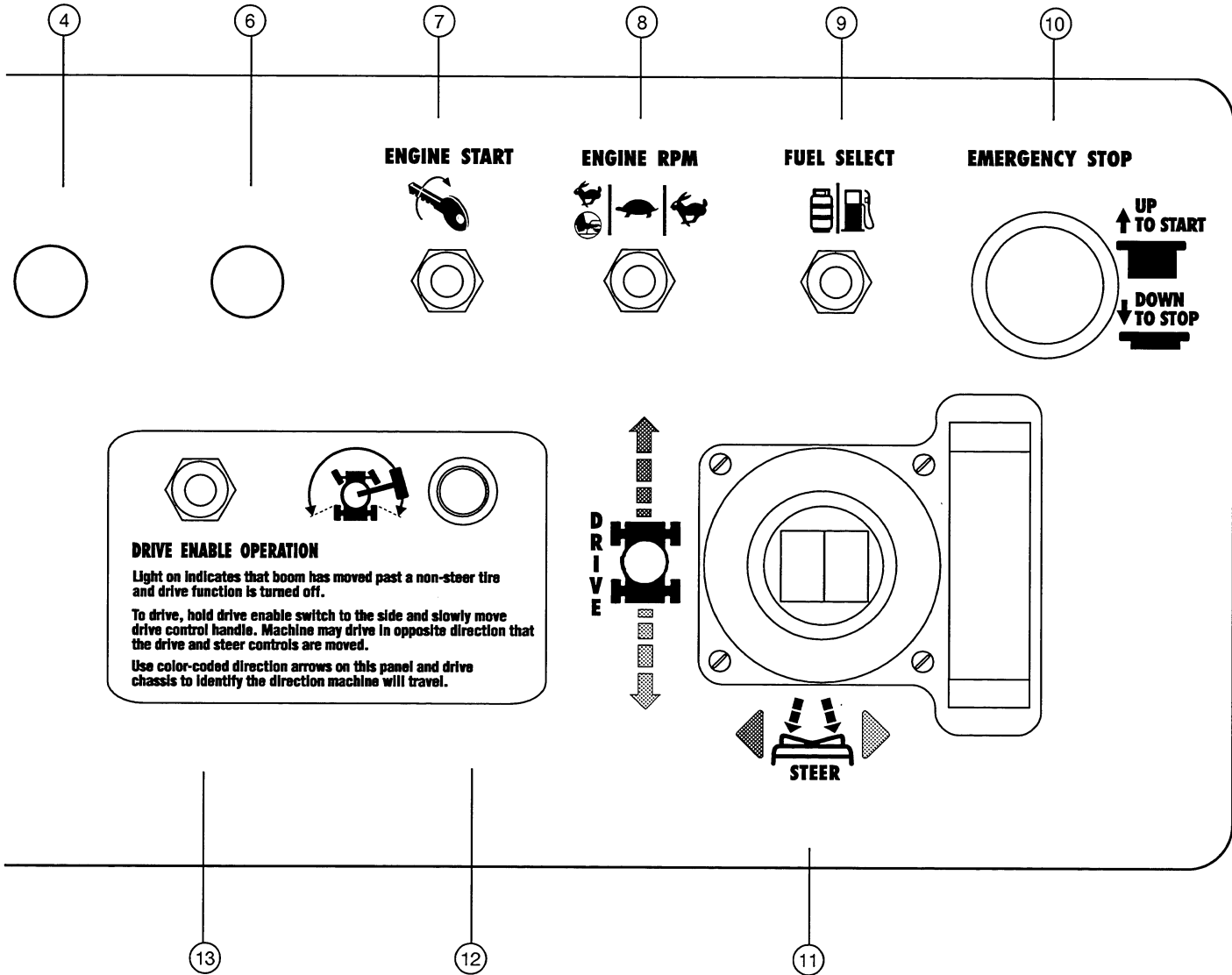

- 11 Proportional control handle for drive function and thumb rocker for steer function
- 12 Drive enable indicator light
- 13 Drive enable switch
- 14 Boom extend/retract switch
- 15 Dual axis proportional control handle for boom up/down and turntable rotate left/right functions

CONTROLS

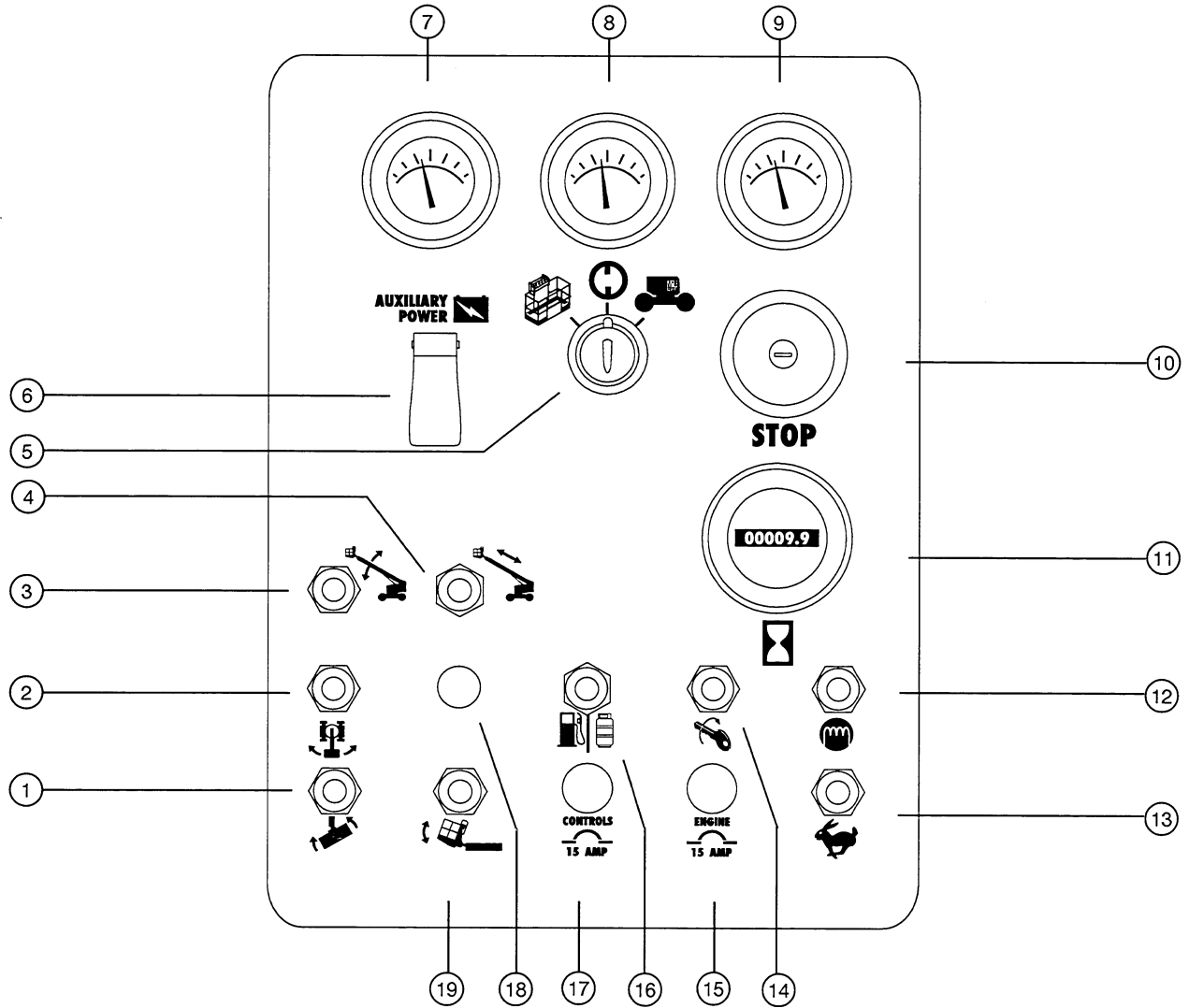

Ground Control Panel

- | | |
|--|---|
| 1 Platform rotate switch | 10 Emergency Stop button |
| 2 Turntable rotate switch | 11 Hour meter |
| 3 Boom up/down switch | 12 Deutz Diesel models: Glow plug switch (option) |
| 4 Boom extend/retract switch | 13 Engine high idle (rpm) switch |
| 5 Key switch for platform/off/ground selection | 14 Engine start switch |
| 6 Auxiliary power switch with cover | 15 15A breaker for engine electrical circuits |
| 7 Gasoline/LPG models: Water temperature gauge
Deutz Diesel models: Oil temperature gauge | 16 Gasoline/LPG select switch |
| 8 Oil pressure gauge | 17 15A breaker for control electrical circuits |
| 9 Voltage gauge | 18 not used |
| | 19 Platform level switch |

Pre-operation Inspection



Do Not Operate Unless:

- You learn and practice the principles of safe machine operation contained in this operator's manual.
 - 1 Avoid hazardous situations.
 - 2 Always perform a pre-operation inspection.**
- Know and understand the pre-operation inspection before going on to the next section.**
- 3 Always perform function tests prior to use.
- 4 Inspect the work place.
- 5 Only use the machine as it was intended.

Fundamentals

It is the responsibility of the operator to perform a Pre-operation Inspection.

The Pre-operation Inspection is a visual inspection performed by the operator prior to each work shift. The inspection is designed to discover if anything is apparently wrong with a machine before the operator performs the function tests.

Refer to the list on page 10 and check each of the items and locations for modifications, damage or loose or missing parts.

A damaged or modified machine must never be used. If damage or any variation from factory delivered condition is discovered, the machine must be tagged and removed from service.

Repairs to the machine may only be made by a qualified service technician, according to the manufacturer's specifications. After repairs are completed, the operator must perform a pre-operation inspection again before going on to the function tests.

Scheduled maintenance inspections shall be performed by qualified service technicians, according to the manufacturer's specifications and the requirements listed in the responsibilities manuals.

PRE-OPERATION INSPECTION**Pre-operation Inspection**

- Be sure that the operator's, safety and responsibilities manuals are legible and in the storage container located on the platform.
- Be sure that all decals are legible and in place (see Decals, page 20).
- Check the hydraulic power unit oil level. Check for leaks.

Check the following components or areas for damage, modifications and improperly installed or missing parts:

- Electrical components, wiring and electrical cables
- Hydraulic hoses, fittings, cylinders and manifolds
- Fuel and hydraulic tanks
- Drive and turntable motors and torque hubs
- Boom wear pads
- Tires and wheels
- Engine and related components
- Limit switches, alarms, horn and beacon
- Nuts, bolts and other fasteners
- Platform entry mid-rail/gate

Check entire machine for:

- Cracks in welds or structural components
- Dents or damage to machine
- Be sure that all structural and other critical components are present and all associated fasteners and pins are in place and properly tightened.
- After you complete your inspection, be sure that all compartment covers are in place and latched.

Function Tests



Do Not Operate Unless:

- You learn and practice the principles of safe machine operation contained in this operator's manual.

- 1 Avoid hazardous situations.

- 2 Always perform a pre-operation inspection.

- 3 Always perform function tests prior to use.**

Know and understand the above principles before going on to the next section.

- 4 Inspect the work place.

- 5 Only use the machine as it was intended.

Fundamentals

The Function Tests are designed to discover any malfunctions before the machine is put into service. The operator must follow the step-by-step instructions to test all machine functions.

A malfunctioning machine must never be used. If malfunctions are discovered, the machine must be tagged and removed from service. Repairs to the machine may only be made by a qualified service technician, according to the manufacturer's specifications.

After repairs are completed, the operator must perform a pre-operation inspection and function tests again before putting the machine into service.

FUNCTION TESTS

- 1 Select a test area that is firm, level and free of obstruction.

At the Ground Controls

- 2 Turn the key switch to ground control.
- 3 Pull out the red Emergency Stop button to the ON position.
- ⦿ Result: Beacon (if equipped) should flash.
- 4 Start the engine (see *Starting The Engine*, page 16).

Test Emergency Stop

- 5 Push in the red Emergency Stop button to the OFF position.
- ⦿ Result: Engine should turn off and all functions should not operate.
- 6 Pull out the red Emergency Stop button to the ON position and restart the engine.

Test the Machine Functions

- 7 Activate each boom and platform function toggle switch.
- ⦿ Result: All boom and platform functions should operate through a full cycle. Descent alarm (if equipped) should sound while boom is lowering.

Test the Tilt Sensor

- 8 Pull out the platform red Emergency Stop button to the ON position. Turn the key switch to platform control.
- 9 Open the tank side turntable cover and locate the tilt sensor next to the control box.
- 10 Press down one side of the tilt sensor.

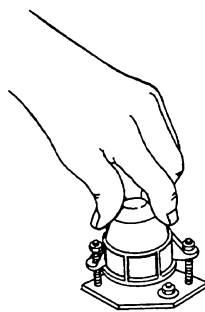

- ⦿ Result: The alarm, located in the platform, should sound.

Test Auxiliary Controls

- 11 Turn the key switch to ground control and shut the engine off.
- 12 Pull out the red Emergency Stop button to the ON position.
- 13 Lift the red auxiliary power switch cover.
- 14 Simultaneously hold the auxiliary power switch on and activate each boom function toggle switch.

Note: To conserve battery power, test each function through a partial cycle.

- ⦿ Result: All boom functions should operate.

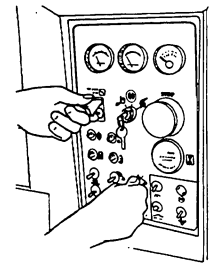
**At the Platform Controls****Test Emergency Stop**

- 15 Turn the key switch to platform control and restart the engine.
- 16 Push in the platform red Emergency Stop button to the OFF position.
- ⦿ Result: The engine should turn off and all functions should not operate.
- 17 Pull out the red Emergency Stop button and restart the engine.

Test the Service Horn

- 18 Push the horn button.
- ⦿ Result: The service horn should sound.

Test the Foot Switch

- 19 Push in the platform Emergency Stop button to the OFF position.
- 20 Pull out the Emergency Stop button to the ON position but do not start the engine.

FUNCTION TESTS

21 Press down the foot switch and attempt to start engine by moving the start toggle switch to either side.

- ⦿ Result: The engine should **not** start.

22 Do not press down the foot switch and restart engine.

23 Do not press down the foot switch. Then test each machine function.

- ⦿ Result: The machine functions should **not** operate.

Test Machine Functions

24 Press down the foot switch.

25 Activate each machine function control handle or toggle switch.

- ⦿ Result: All boom/platform functions should operate through a full cycle.

Test the Steering

26 Press down the foot switch.

27 Depress the thumb rocker switch on top of the drive control handle in the direction identified by the blue triangle on the control panel.

- ⦿ Result: The steer wheels should turn in the direction that the blue triangles point on the drive chassis.

28 Depress the thumb rocker switch in the direction identified by the yellow triangle on the control panel.

- ⦿ Result: Steer wheels should turn in the direction that the yellow triangles point on the drive chassis.

Test Drive and Braking

29 Press down the foot switch.

30 Slowly move the drive control handle in the direction indicated by the blue arrow on the control panel until the machine begins to move, then return the handle to the center position.

- ⦿ Result: The machine should move in the direction that the blue arrow points on the drive chassis, then come to an abrupt stop.

31 Slowly move the drive control handle in the direction indicated by the yellow arrow on the control panel until the machine begins to move, then return the handle to the center position.

- ⦿ Result: The machine should move in the direction that the yellow arrow points on the drive chassis, then come to an abrupt stop.

Note: The drive brakes must be able to hold the machine on any slope it is able to climb.

Test the Oscillate Axle (oscillating axle-equipped models)

32 Start the engine from the platform controls.

33 Drive the right steer tire up onto a 6 inch (15.2 cm) block or curb.

- ⦿ Result: The three remaining tires should stay in firm contact with the ground.

34 Drive the left steer tire up onto a 6 inch (15.2 cm) block or curb.

- ⦿ Result: The three remaining tires should stay in firm contact with the ground.

35 Drive both steer tires up onto a 6 inch (15.2 cm) block or curb.

- ⦿ Result: The non-steer tires should stay in firm contact with the ground.

FUNCTION TESTS

Test the Drive Enable System

- 36 Press down the foot switch. Then lower the boom to the stowed position.
- 37 Rotate the turntable until the boom moves past one of the non-steering wheels.

⊙ Result: The drive enable indicator light should come on and remain on while the boom is anywhere in the range shown.



- 38 Move the drive control handle off center.

⊙ Result: The drive function should **not** operate.

- 39 Move and hold the drive enable toggle switch to either side and slowly move the drive control handle off center.

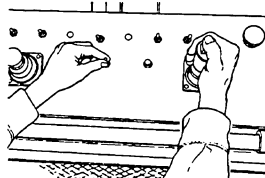

⊙ Result: The drive function should operate.

Note: When the drive enable system is in use, the machine may drive in the opposite direction that the drive and steer control handle is moved.

Use the color-coded direction arrows on the platform controls and the drive chassis to identify the direction of travel.

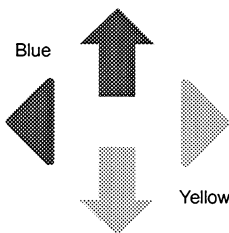

Test Limited Drive Speed

- 40 Press down the foot switch.
- 41 Raise the boom to just above horizontal.



- 42 Slowly move the drive control handle to the full drive position.

⊙ Result: The maximum achievable drive speed with the boom raised should not exceed 1 foot per second (0.3 meters per second).

- 43 Lower the boom to the stowed position.

- 44 Extend the boom 1 foot (30 cm).

- 45 Slowly move the drive control handle to the full drive position.

⊙ Result: The maximum achievable drive speed with the boom extended should not exceed 1 foot per second (0.3 meters per second).

If the drive speed with the boom raised or extended exceeds 1 foot per second (0.3 meters per second), immediately tag and remove the machine from service.

Test Auxiliary Controls

- 46 Shut off the engine.
- 47 Pull out the red Emergency Stop button to the ON position.
- 48 Press down the foot switch.
- 49 Lift the red auxiliary power switch cover.

- 50 Simultaneously hold auxiliary power switch on and activate each function control handle or toggle switch.

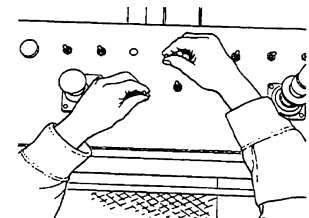

Note: To conserve battery power, test each function through a partial cycle.

⊙ Result: All boom and steer functions should operate. Drive functions should not operate with auxiliary power.

- 51 Repair any malfunctions before operating the machine.

Work Place Inspection



Do Not Operate Unless:

- You learn and practice the principles of safe machine operation contained in this operator's manual.
 - 1 Avoid hazardous situations.
 - 2 Always perform a pre-operation inspection.
 - 3 Always perform function tests prior to use.
 - 4 Inspect the work place.**

Know and understand the above principles before going on to the next section.

- 5 Only use the machine as it was intended.

Work Place Inspection

Be aware of and avoid the following hazardous situations:

- drop-offs or holes
- bumps, floor obstructions or debris
- overhead obstructions and high voltage conductors
- hazardous locations
- inadequate surface support to withstand all load forces imposed by the machine
- wind and weather conditions
- the presence of unauthorized personnel
- other possible unsafe conditions

Fundamentals

The Work Place Inspection helps the operator determine if the work place is suitable for safe machine operation. It should be performed by the operator prior to moving the machine to the work place.

It is the operator's responsibility to read and remember the work place hazards, then watch for and avoid them while moving, setting up and operating the machine.

Operating Instructions



Do Not Operate Unless:

- ☑ You learn and practice the principles of safe machine operation contained in this operator's manual.
 - 1 Avoid hazardous situations.
 - 2 Always perform a pre-operation inspection.
 - 3 Always perform function tests prior to use.
 - 4 Inspect the work place.
 - 5 Only use the machine as it was intended.**

Fundamentals

The Operating Instructions section provides instructions for each aspect of machine operation. It is the operator's responsibility to follow all the safety rules and instructions in the operator's, safety and responsibilities manuals.

Using the machine for anything other than lifting personnel and tools to an aerial work site is unsafe and dangerous.

Only trained and authorized personnel should be permitted to operate a machine. If more than one operator is expected to use a machine at different times in the same work shift, they must all be qualified operators and are all expected to follow all safety rules and instructions in the operator's, safety and responsibilities manuals. That means every new operator should perform a pre-operation inspection, function tests, and a work place inspection before using the machine.

Starting the Engine

- 1 At the ground controls, turn the key switch to the desired position.
- 2 Be sure both ground and platform control red Emergency Stop buttons are pulled out to the ON position.
- 3 Gasoline/LPG models: Choose fuel by moving the fuel select switch to the desired position.
- 4 Move the engine start toggle switch to either side. If engine fails to start or dies, the restart delay will disable the start switch for 3 seconds.



If engine fails to start after 15 seconds of cranking, determine cause and repair any malfunction. Wait 60 seconds before trying to start again.

All models: In extreme cold conditions, 20°F (-6°C) and below, warm engine for 5 minutes to prevent hydraulic system damage.

Gasoline/LPG models: In extreme cold conditions, 20°F (-6°C) and below, machine should be started on gasoline, then switched to LPG.

Emergency Stop

Push in either ground or platform red Emergency Stop button to the OFF position to stop all functions and turn engine off.

Repair any function that operates when the Emergency Stop button is pushed in.

Selecting and operating the ground controls will override the platform Emergency Stop button.

OPERATING INSTRUCTIONS

Auxiliary Controls

Use auxiliary power if the primary power source (engine) fails.

- 1 Turn the key switch to ground or platform control.
- 2 Pull out the red Emergency Stop button to the ON position.
- 3 Press down the foot switch when operating the auxiliary controls from the platform.
- 4 Simultaneously hold auxiliary power switch ON and activate desired function.

The drive function will not operate with auxiliary power.

Operation from Ground

- 1 Turn the key switch to ground control.
- 2 Pull out the red Emergency Stop button to the ON position.
- 3 Gasoline/LPG models: Choose fuel by moving fuel select switch to desired position.
- 4 Start the engine.

To Position Platform

- 1 Move the appropriate toggle switch according to markings on the control panel.

Drive and steer functions are not available from the ground controls.

Operation from Platform

- 1 Turn the key switch to platform control.
- 2 Pull out both ground and platform red Emergency Stop buttons to the ON position.
- 3 Gasoline/LPG models: Choose fuel by moving fuel select switch to desired position.
- 4 Start engine. Do not press down the foot switch when starting engine.

To Position Platform

- 1 Press down the foot switch.
- 2 Slowly move the appropriate function control handle or toggle switch according to the markings on the control panel.

To Steer

- 1 Press down the foot switch.
- 2 Turn the steering wheels with the thumb rocker switch located on top of the drive control handle.

Use the color-coded direction arrows on the platform controls and the drive chassis to identify the direction wheels will turn.

To Drive

- 1 Press down the foot switch.
- 2 Increase speed: Slowly move the drive control handle off center.
Decrease speed: Slowly move the drive control handle toward center.
Stop: Return the drive control handle to center or release the foot switch.

Use the color-coded direction arrows on the platform controls and the drive chassis to identify the direction machine will travel.

Machine travel speed is restricted when the boom is raised or extended.

OPERATING INSTRUCTIONS

Drive Enable

Light ON indicates that the boom has moved just past either non-steering wheel and drive function has been interrupted.

To drive, hold the drive enable switch to either side and slowly move the drive control handle off center.

Be aware that the machine may move in the opposite direction that the drive and steer controls are moved.

Always use the color-coded direction arrows on the platform controls and the drive chassis to identify the direction machine will travel.

Engine Idle Select (rpm)

Select engine idle (rpm) using the symbols on the control panel.

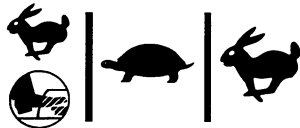

- Rabbit and foot switch symbol: foot switch activated high idle
- Turtle symbol: low idle
- Rabbit symbol: high idle

Stopping the Engine

Push in the red Emergency Stop button and turn the key switch to the OFF position.

After Each Use

- 1 Select a safe parking location—firm level surface, clear of obstruction and traffic.
- 2 Retract and lower the boom to the stowed position.
- 3 Rotate the turntable so that the boom is between the non-steering wheels.
- 4 Turn the key switch to the OFF position and remove the key to secure from unauthorized use.
- 5 Chock the wheels.

OPERATING INSTRUCTIONS



**Transport Instructions
Observe and Obey:**

- Transport vehicle must be parked on a level surface.
- Transport vehicle must be secured to prevent rolling while machine is being loaded.
- Be sure vehicle capacity, loading surfaces and straps or lines are sufficient to withstand machine weight (see *Specifications*, page 23).

Securing to Truck or Trailer for Transit

- Always use the turntable rotation lock pin each time the machine is transported.
- Always chock machine wheels in preparation for transport.
- Use tie points on drive chassis for anchoring down to transport surface.
- Use lower platform mount between boom end and platform to secure boom from side-to-side movement. Do not use excessive downward force when securing boom section.
- Use chains or straps of ample load capacity.
- Turn key switch to the OFF position and remove key before transporting.
- Inspect entire machine for loose or unsecured items.

Free-wheel Configuration for Winching

Chock wheels to prevent machine from rolling.
 2WD models: Release non-steer wheel brakes by turning over torque hub disconnect caps (see below).

4WD models: Release wheel brakes by turning over all four torque hub disconnect caps (see below).

Be sure winch line is properly secured to drive chassis tie points and path is clear of all obstructions.

Reverse procedures described to re-engage brakes.

Note: The pump free-wheel valve should always remain closed.

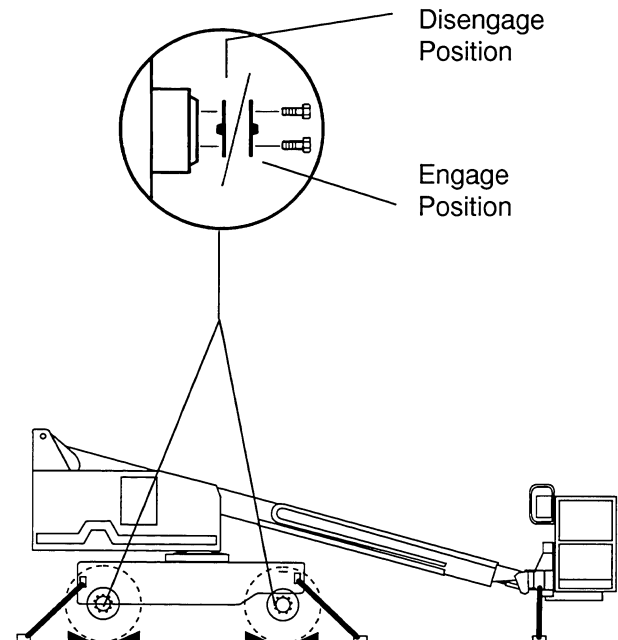

Decals

Index	Part No. Decal Description	Quantity
1	28157 Label - Dexron	1
2	28158 or 28159 Label - Unleaded or Label - Diesel	2
3	32744 "S"	2
4	32702 Notice - Operating Instructions	2
5	32658 Ground Control Panel	1
6	25994 Caution - Comp. Dam. - Hydraulic Valves	1
7	27564 Danger - Electrocution Hazard	3
8	32720 Serial Plate	1
9	1699 Safety Tape	
10	28177 Warning - Platform Rotate	2
11	32719 Notice - Tire Pressure	2
12	32700 Danger - General Safety Rules	2
13	28161 Warning - Crush Hand	3
14	28171 Label - No Smoking	2
15	30406 or 30407 Genie 2WD or Genie 4WD	2
16	28174 or 28235 Power to Platform or Power to Platform 220V 115V	2
17	28181 Warning - No Step or Ride	1
18	28160 Label - LPG	1
19	28164 Notice - Hazardous Materials	1
20	28175 Caution - Compartment Access	1



Shading indicates decal is hidden from view, i.e. under covers

Index	Part No. Decal Description	Quantity
22	32703 or 33956 Notice Notice - Ford LSG Engine Specs Ford LRG Engine specs or 32721 Notice - Deutz Engine Specs	
22	32745 Genie S-40	1
23	32747 Stripes	1
24	33952 Danger - Tilt-Alarm	1
25	32657 Platform Control Panel	1
26	32726 Option, Glow Plugs	1
26	32728 Option, Generator	1
27	28165 Notice - Foot Switch	1
28	30080 Notice - Max Load 500 lbs.	1
29	28236 Warning - Failure To Read . . .	1
30	28176 Notice - Missing Manuals	1
31	28163 Notice - Maximum Allowable Side Force	1
32	28867 Genie BOOM	2
33	32746 Genie S-40	1
34	27207 Triangle, Yellow	2
35	27205 Arrow, Yellow	1
36	27206 Triangle, Blue	2
37	27204 Arrow, Blue	1
38	31060 Danger - Do Not Alter Limit Switch	1

DECALS

Tank Side

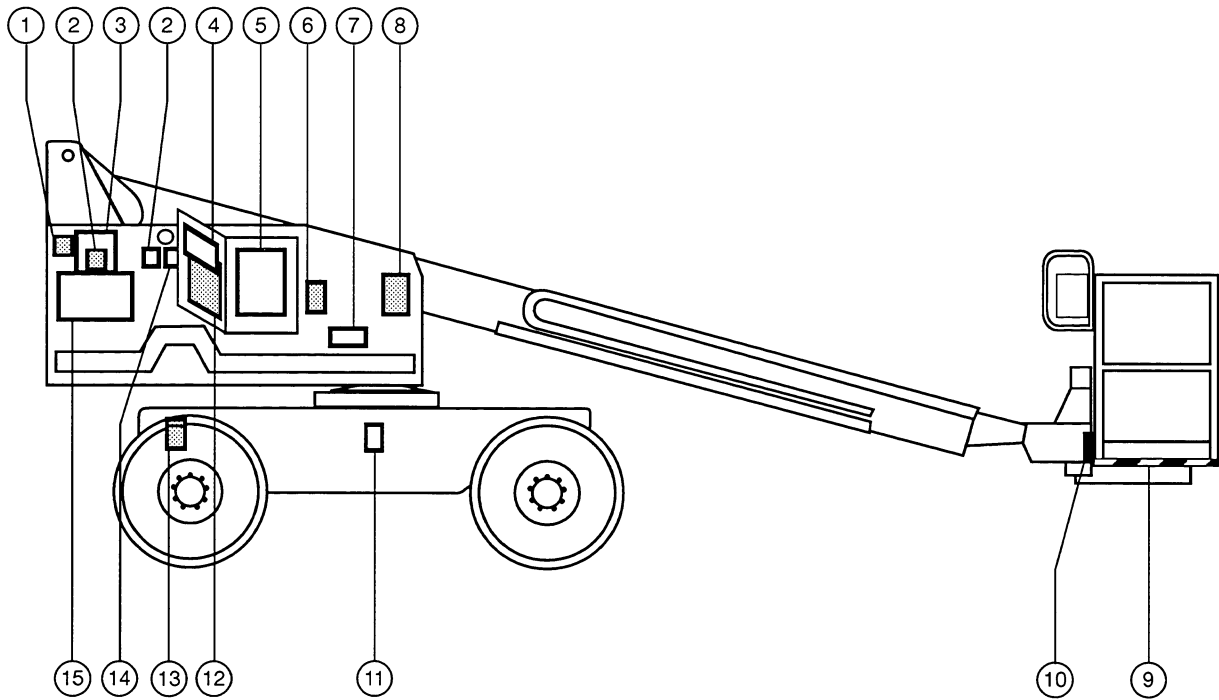

Engine Side

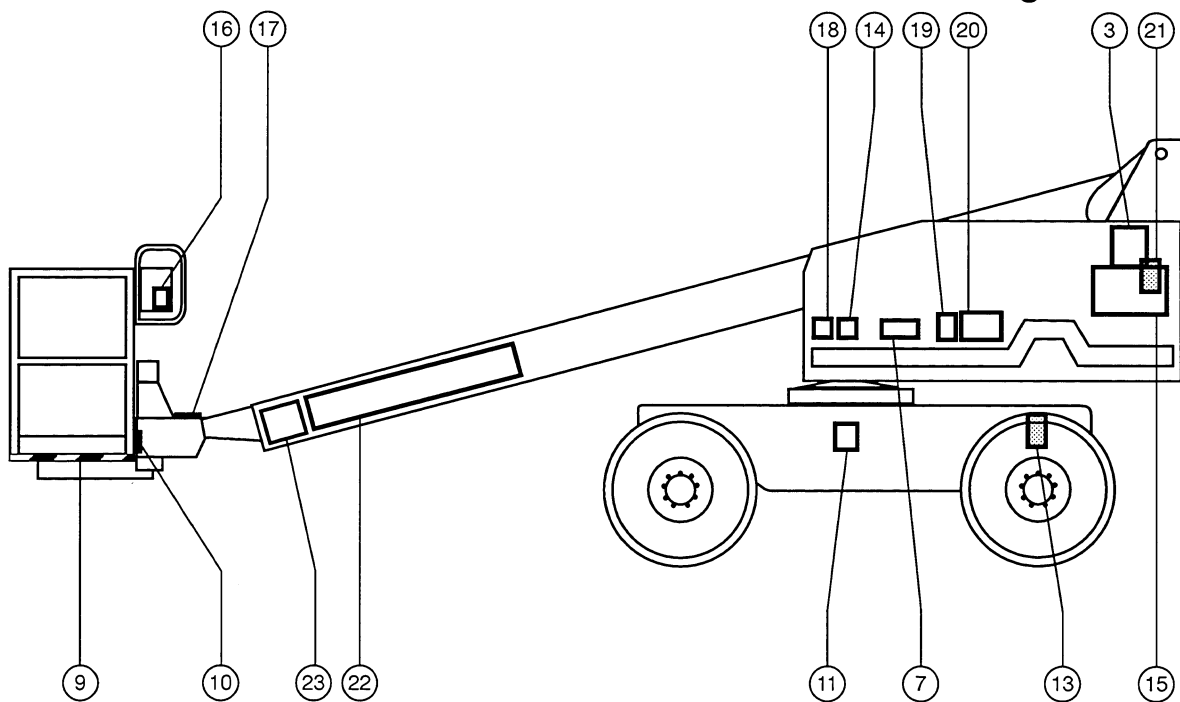

DECALS

Turntable - Boom Storage End

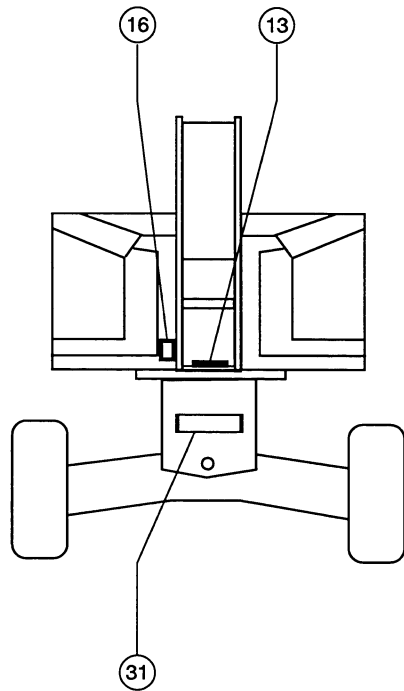

Platform

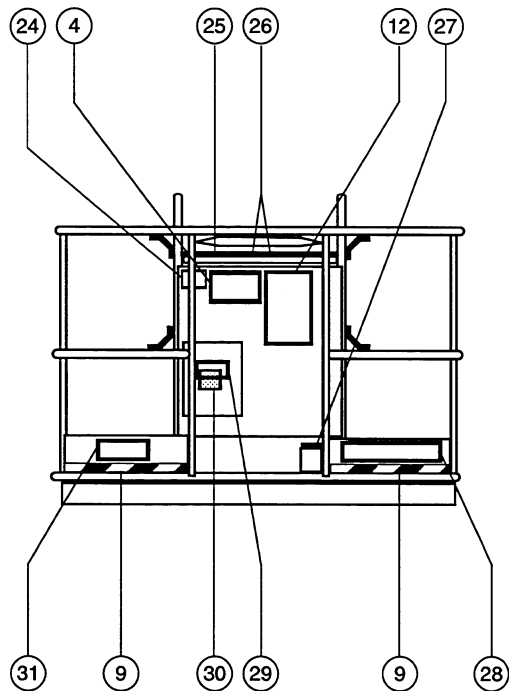

Turntable - Boom Pivot End

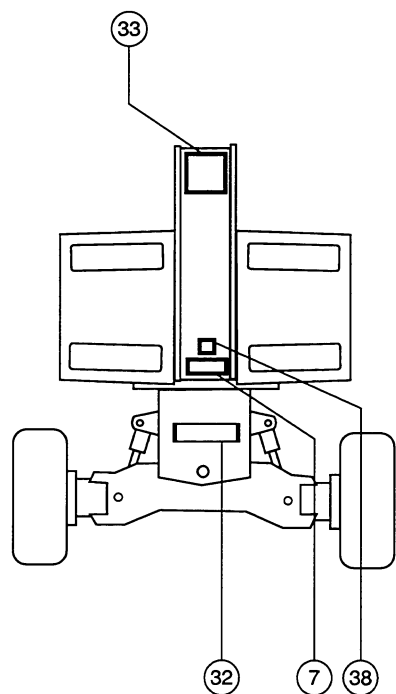

Drive Chassis - Top

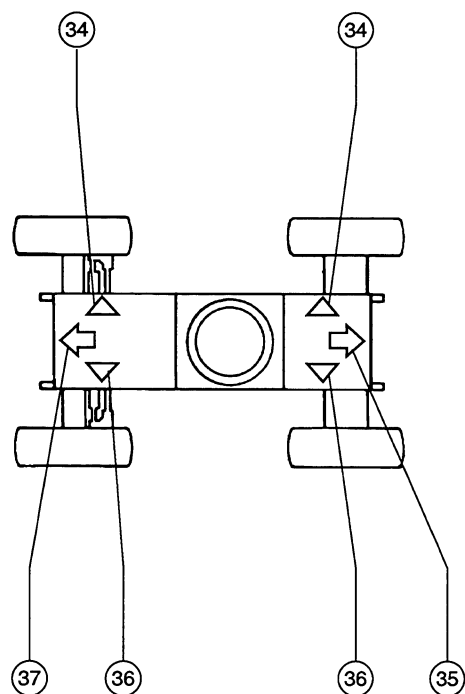

Specifications

Model	2WD/RT	4WD/RT
Height, working maximum	46 ft 14 m	46 ft 14 m
Height, platform maximum	40 ft 12.2 m	40 ft 12.2 m
Height, stowed maximum	8 ft 2 in 2.48 m	8 ft 2 in 2.48 m
Horizontal reach maximum	31 ft 8 in 9.64 m	31 ft 8 in 9.64 m
Width	7 ft 6 in 2.29 m	7 ft 6 in 2.29 m
Length, stowed	23 ft 11 in 7.28 m	23 ft 11 in 7.28 m
Maximum load capacity 6 foot platform	500 lb 227 kg	500 lb 227 kg
Maximum load capacity 8 foot platform	500 lb 227 kg	500 lb 227 kg
Wheelbase	7 ft 3 in 2.2 m	7 ft 3 in 2.2 m
Turning radius (outside)	15 ft 8 in 4.77 m	15 ft 8 in 4.77 m
Turning radius (inside)	6 ft 8 in 2.02 m	6 ft 8 in 2.02 m
Turntable rotation (degrees)	continuous	
Turntable tailswing	34 in 86.4 cm	34 in 86.4 cm
Power source (choice)	Ford 63 Hp Gasoline/LPG LSG/LRG-423 Deutz 36 Hp Diesel F3L 1011	
Drive speed, stowed Gasoline/LPG models	4.0 mph 6.4 km/h	3.5 mph 5.6 km/h
	40 ft/6.8 sec 12.2 m/6.8 sec	40 ft/7.8 sec 12.2 m/7.8 sec
Drive speed, stowed Deutz Diesel models	3.5 mph 5.6 km/h	3 mph 4.8 km/h
	40 ft/7.8 sec 12.2 m/7.8 sec	40 ft/9.1 sec 12.2 m/9.1 sec

Continuous improvement of our products is a Genie policy. Product specifications are subject to change without notice or obligation.

Model	2WD/RT	4WD/RT
Drive speed, raised or extended - all models	0.68 mph 1.1 km/h	0.68 mph 1.1 km/h
	40 ft/40 sec 12.2 m/40 sec	40 ft/40 sec 12.2 m/40 sec
Controls	12V DC proportional	
Platform dimensions, 6 foot (length x width)	72 in x 30 in 1.8 m x 76 cm	72 in x 30 in 1.8 m x 76 cm
Platform dimensions, 8 foot (length x width)	96 in x 36 in 2.4 m x 91 cm	96 in x 36 in 2.4 m x 91 cm
Platform leveling	self-leveling	self-leveling
Platform rotation	160°	160°
AC outlet in platform	standard	standard
Hydraulic pressure (maximum) (boom functions)	2500 psi 172 bar	2500 psi 172 bar
Tire size, 2WD front tires only		12.5L-16SL
Tire size, 2WD rear 4WD front & rear		12-16.5 NHS
Gradeability, stowed	30%	40 %
Ground clearance	12 1/2 in 31.8 cm	12 1/2 in 31.8 cm
Hydraulic tank capacity	45 gallons	170 liters
Fuel tank capacity	30 gallons	114 liters
Weight	11,650 lbs 5,284 kg	11,650 lb 5,284 kg

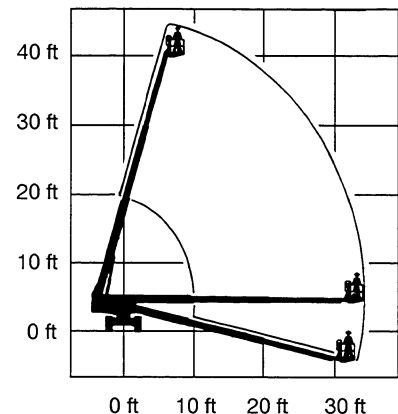

California Proposition 65

!WARNING!

The engine exhaust from this product contains chemicals known to the State of California to cause cancer, birth defects or other reproductive harm.



Genie North America

18340 NE 76th Street
P.O. Box 97030
Redmond, Washington
98073-9730



Genie Europe

Brunel Drive
Newark
Nottinghamshire
NG24 2EG England